

RISE

UNDERFLOOR HEATING

ELECTRIC UNDERFLOOR HEATING CABLE



INSTALLATION MANUAL



HEATING HOMES FOR THE FUTURE

OUR AMBITION IS SIMPLE. TO PREPARE HOMES FOR THE FUTURE

Rise underfloor heating solutions are no nonsense and uncomplicated. We simply use the best technologies, premium materials and rigorously test our products to give you peace of mind when it comes to your home. Underfloor heating is an essential, our trusted products are easy to fit and affordable helping you to prepare your home for the future.

HERE'S WHAT YOU NEED TO KNOW

Our powerful heating cables help minimize heating costs

Enables you the flexibility of 150-200 watts per m²

Meets all international safety standards
with our use of premium materials

Our lifetime guarantee* and safeguard* promise
protects you and gives you peace of mind

*T&C's apply



CONTENTS

- 4 Quality you can trust
- 5 Have you got everything you need?
- 6 How do I calculate the correct sized heating system?
- 7 What heating output should I have?
What controls do I need?
What electrical preparations do I need to make?
- 9 Do's & don'ts
- 10 Step-by-step installation instructions
- 22 Underfloor heating warranty
- 23 Test report

QUALITY YOU CAN TRUST

Our loose cable underfloor heating systems have two layers of FEP insulation around the heating cables, ensuring they meet class 2 standards with an earth braid, making them the finest systems available and suitable for use on any sub-floor and in any room. All the systems have been rigorously tested and surpass all European and International standards for use on timber or solid sub-floors. The heating systems are comprised of fixed lengths of heating cable that come with a roll of double-sided self-adhesive tape for easy installation. These systems are designed for use **only under tiled floors** and **for indoor use only**.

If you are intending to install your underfloor heating under other floor finishes, please contact our technical helpline on **0800 246 5963** for advice.



Wire diameter approximately 2mm and is made up of tough fluoropolymer coatings for inner and outer insulation.

- A** Multi-strand twin conductor heating element
- B** Fluoropolymer inner insulation
- C** Earth braid
- D** Fluoropolymer outer insulation

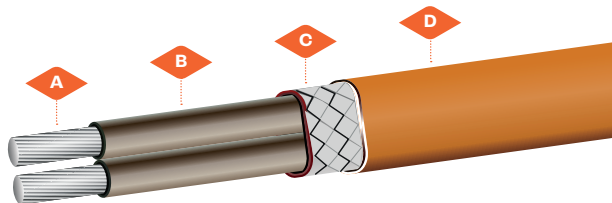

HAVE YOU GOT EVERYTHING YOU NEED?

Components included in your underfloor heating kit:



UNDERFLOOR HEATING CABLE



DOUBLE SIDED ADHESIVE TAPE



INSTALLATION MANUAL



WHAT YOU NEED TO FIT YOUR ELECTRICAL UNDERFLOOR HEATING SYSTEM

- Correct size kit - see page 6
- A suitable thermostat (we recommend our Rise thermostats)
- RCD on the supply (30mA Residual Current Device)
- A suitable flexible tile adhesive or levelling compound
- We recommend the use of a digital multi-meter set to a range of 0-2 K ohms for testing.
- Electrical housing, back boxes and junction boxes. (Back box for the thermostat must be at least 35mm deep) - see page 7

We do not guarantee systems that have not been fitted in accordance with these installation instructions.

Please note: All electrical connections must conform to the current BS 7671 Wiring Regulations. Final connections to the main electricity supply MUST be completed by a Part P qualified electrician and must be connected to an RCD not exceeding 30mA (protected) supply on the consumer unit.

HOW DO I CALCULATE THE CORRECT SIZED HEATING SYSTEM?

Allowing for a 10cm margin around the perimeter of the room, calculate the floor area in m² by multiplying the width by the length. The heating cable should only be laid in open areas of the floor, so you should deduct the area of any fixed furniture such as kitchen or bathroom units from the total floor area.

CALCULATING THE KIT YOU NEED

By spacing the heating cable (between 6cm and 8cm) you can create different wattages from 150 to 200 watts per square metre. In very large areas you may require less heat per m² and then can fit more meterage on a thermostat. If you are looking to warm your floor and take the chill of your tiles we would recommend 150 watts. If you are looking to use underfloor heating as your primary heat source opt for 200 watts.

Have a look at our simple chart below that explains what kits you will need for your project.

- 1 Calculate what size you need and the wattage you require for your project and order the correct size kit.
- 2 If the area size is larger than the individual kit just add kits together at the same wattage per m².

| Kits required | Power (Watts) | Average Covered at 200w | Average Covered at 175w | Area covered at 150w |
|----------------------------------|---------------|-------------------------|-------------------------|------------------------|
| Kit | Watts | Warmest | Warmer | Standard warmth |
| Spacing between the cable | | 6cm spacing | 7cm spacing | 8cm spacing |
| 300w kit | 300w | 1.5m ² | 1.7m ² | 2.0m ² |
| 450w kit | 450w | 2.25m ² | 2.5m ² | 3.0m ² |
| 600w kit | 600w | 3.0m ² | 3.4m ² | 4.0m ² |
| 1500w kit | 1500w | 7.5m ² | 8.6m ² | 10.0m ² |

FREQUENTLY ASKED QUESTIONS

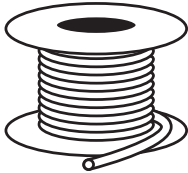

WHAT ELSE DO I NEED TO INSTALL AN UNDERFLOOR HEATING SYSTEM?

All you need is the correct heating system, a control (timer/thermostat) and an RCD.



WHAT HEATING OUTPUT SHOULD I HAVE?

The power depends very much on the heating performance you expect from your system.

150 Watt/m² = Warming
175 Watt/m² = Extra heat
200 Watt/m² = Maximum heat

If there is no insulation in the floor, we can supply tile-backer insulation boards that can be installed on top of your existing sub-floor. Thermostats are normally rated at 16 amps, if installing more than one cable make sure the overall wattage doesn't exceed 3600 watts.



WHAT CONTROLS DO I NEED?

You will need to install a timer/thermostat which will allow you to have total control of your heating whilst ensuring maximum efficiency. We recommend the Rise Wi-Fi or Smart Wi-Fi Thermostats which allow you to control the temperature with your phone or tablet via an app.



WHAT ELECTRICAL PREPARATIONS DO I NEED TO MAKE?

You will need a qualified electrician for the connection of the thermostat. The electrician will need to provide the correct size spur and deep single back boxes for the control and Residual Current Device (RCD). An RCD is only required if you do not already have one on the mains.



PLEASE READ THE DO'S AND DON'TS TO ENSURE YOUR HEATING SYSTEM IS FITTED CORRECTLY.

DO

- Carefully read this instruction manual before commencing installation.
- Consult our helpline if you are unsure how to proceed.
- Ensure the system is tested before, during and after installation.
- Plan your loose cable layout and installation so that any drilling after tiling (e.g. for sanitary ware) will not damage the heating.
- Ensure that the maximum thermal resistance of the floor does not exceed 0.15 [m²K / W].
- Ensure that during the installation no damage is caused by sharp objects etc.
- Maintain a minimum gap of 60mm between wire runs and from conductive parts.
- Ensure the end cap and manufactured joint are under a full bed of adhesive or levelling compound.
- Check that the loose cable is working immediately before commencing tiling.
- Take care when tiling not to dislodge or damage the heating wire.
- Ensure that the heaters are separated from other heat sources.
- Ensure that the warranty card at the back of the manual is completed and fixed at the main consumer unit along with any plans and electrical test records. As per the current BS7671:2008 17th Edition Wiring Regulations.
- Use flexible tile adhesive to allow for any small floor movement that may occur on a de-coupling membrane if installing on a wooden sub-floor.
- Ensure heating elements are always protected by an RCD.
- Use a qualified electrician to connect the heating element to the mains.
- Ensure the cold tail connection is laid flat and not bent in anyway. Do not leave the connection between the cable and the connection wire exposed - always cover the connection with adhesive/levelling compound.

DON'T

- Commence installation on a concrete floor that has not fully cured.
- Install the loose cable on irregular surfaces such as stairs or up walls.
- Use staples to secure the heating element to the sub-floor.
- Shorten the heating element at any time.
- Leave surplus wire rolled up under units or fixtures - USE THE CORRECT SIZE
- Run the floor sensor wire or power lead over or under the heating element or close to other heat sources such as hot water pipes.
- **Tape over the end cap or manufactured joint.**
- Commence tiling before testing the wire.
- Switch on the installed loose cable until 14 days after fitting to allow the tile adhesive to dry completely.
- Install the loose cable in temperatures less than +5°C.
- Use the heating wire to dry out levelling compound or adhesive.
- Attempt a DIY repair - if you damage the heating cable contact our technical helpline on 0800 246 5963.
- If you accidentally damage the heating wire BEFORE tiling, return the damaged heating cable to us and we will replace it FREE OF CHARGE as part of our Safeguard Guarantee.



Should not be used under wooden or laminate floor coverings.

Please contact us for further advice if you wish to install the underfloor heating cable under any floor finishes other than ceramic, quarry or natural stone tiles.

STEP 1

PREPARE SUB-FLOOR AND ELECTRICS

A Surface Preparation

The installer should prepare the floor in accordance with modern building regulations as if they were laying ordinary floor tiles. They should ensure that the floor surface is completely smooth and flat and that loose floorboards are repaired.

You will need to make a groove in the sub-floor for the cold lead connection joint, as this is slightly thicker than the heating cables and must be covered with adhesive. Only do this once the position of the heating cable has been finalised. We recommend the application of an suitable tiling primer over the sub-floor especially if installing with self-adhesive mats or tape so the system sticks adequately.



On wooden sub-floors

It is recommended you prime the floor using a suitable tiling primer. Always use a suitable flexible tile adhesive and check with the supplier that they are suitable for use on wooden sub-floors.

Installing on a de-coupling membrane reduces the risk of failure if there is movement in the floor, if installing always follow the advice from the manufacturer.



Concrete/screeded sub-floors

Again, it's a good idea to prime the floor. Always use a suitable flexible tile adhesive.



Insulation/tile backer boards

Use the same installation process as on wooden sub-floors. Check with the board manufacturer to find out if priming is required.

GENERAL INSTRUCTIONS

If you have a **concrete sub-floor with an expansion joint**, the heating cable should be positioned so that it does not cover the joint in case of any movement in the floor.

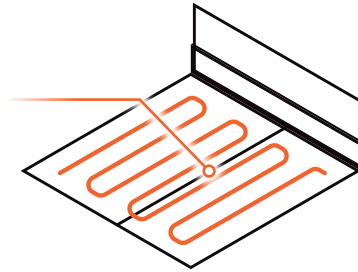

B Electrical preparation

Before laying the heating system, a flush mounted deep electrical box should be installed, this is where the cold leads from the heating cable and the wiring from the controls can be connected. If installing the system in a wet environment such as a bathroom, the regulations stipulate that the connections/controls must not be sited within the room. Usually it is possible to place them on a wall outside the room (as with a light switch). All wiring should be chased into the wall and protected by conduit or trunking.

The wire must be connected to power mains through a double pole circuit breaker of suitable rating, integrated into the fixed wiring system with opening contacts at all poles. The gap between the circuit breaker contacts at all poles must not be less than 3 mm.

In most instances a 13amp spur is enough. However, to calculate the exact loading in amps, there is a simple calculation. Take the total area in m^2 of the heating cable and multiply it by the power rating of the cable, this gives the heating output in watts. To work out the loading, simply divide this amount by the volts.

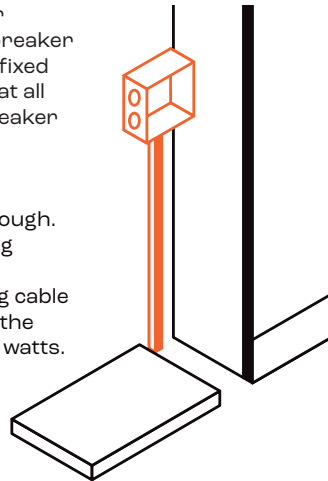

GENERAL INSTRUCTIONS

STEP 2

NOW TEST THE SYSTEM (RESISTANCE)

We recommend that you test the system resistance before you start the installation, and again as you finish the installation/ before fitting the final floor covering. To take a reading set your meter to the ohms position on the lowest setting (normally 8000 or 20000 K/ohms). Hold one of the probes on the blue centre cable and one on the black centre cable, the reading obtained should be as shown on the label. You have now completed the continuity test.

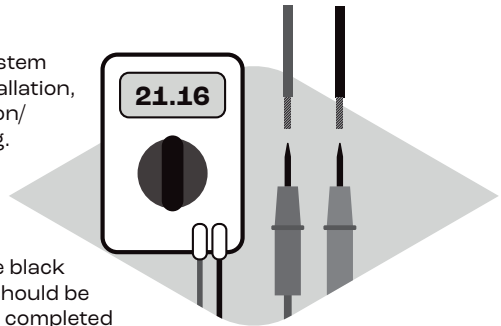

There is the possibility of a degree of variance in the readings that you take during the course of the installation. If this is not too significant (5% either way) you should not worry too much as the reading can be affected by moisture and other factors. We recommend that you test the floor sensor with an ohm reading (generally 8 to 20 ohms). The sensor is covered by the thermostat guarantee (usually between 3-5 years).

Also, an insulation test should be done by checking for resistance between the conductor (blue or black cable) and the earth braid - with the meter on its highest setting (2M Ohms), one probe on either the blue or black cable and the other probe on the earth braid. Do not hold the probes on with your fingers during this test, as this could affect the result. Any resistance should be greater than 2M Ohms, and therefore not register on the meter. Most multi-meters will read as "1".

Fill in your test readings at the back of this booklet.



STEP 3

INSTALLING YOUR UNDERFLOOR HEATING



IF INSTALLING OUR MAT SYSTEM, FOLLOW THE SEPARATE INSTRUCTION SHEET FOR WIRE NOW.

Installing your loose cable system

Heating cables should never be laid beneath permanent furniture (cupboards or bathroom fixtures), therefore, we recommend that you draw up a detailed plan of the areas where the cable will be before you carry out the installation. Decide where you would like the cable and mark them out on the sub-floor.

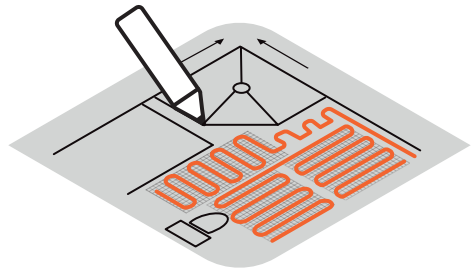

Plan the installation and mark where each run should go to ensure you have the correct size system.

Never join the heating element wires or cross the cold leads underneath or on top of the cable. Our cable comes with a roll of very strong double-sided adhesive tape to stick the cable to the sub-floor.

- A** Start with the cold lead (connection lead) as near to the electrical spur as possible.
- B** From the following table, select your kit according to your area and the appropriate cable spacing.

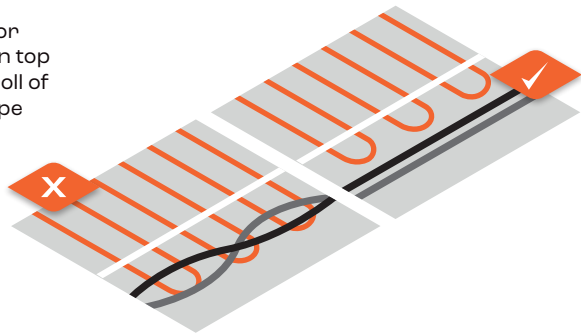

GENERAL INSTRUCTIONS

| Cable kit wattage | Area covered 200w | Area covered 175w | Area covered 150w |
|---------------------|--------------------|--------------------|--------------------|
| Space between cable | 6cm spacing | 7cm spacing | 8cm spacing |
| 300 | 1.50m ² | 1.71m ² | 2.00m ² |
| 450 | 2.25m ² | 2.60m ² | 3.00m ² |
| 600 | 3.00m ² | 3.43m ² | 4.00m ² |
| 1500 | 7.50m ² | 8.57m ² | 10.00 |

Having decided on the cable spacing, we suggest using your tape measure and with a marker pen/ chalk highlight where each cable should be stuck down.

Start from the thermostat point and mark out the spacing intervals for the heating cable.

Try to keep the spacing as uniform as possible to ensure that you do not have hot and cold spots in the floor.

Where you have marked on the floor to begin your installation, lay two rows of double-sided adhesive tape onto the sub-floor across the top of your run. Add a single row of double-sided tape in the middle of the area and finish with two rows at the end of your plan. (For larger areas you may require additional strips of tape throughout the area).

Now bed your heating cable into the tape by pushing it down to make sure it is secure. If any ends are sticking up, again use the tape to adhere them to the floor.

The heating cable has only one connection cable so there is no worry about getting the end back to where you have started.

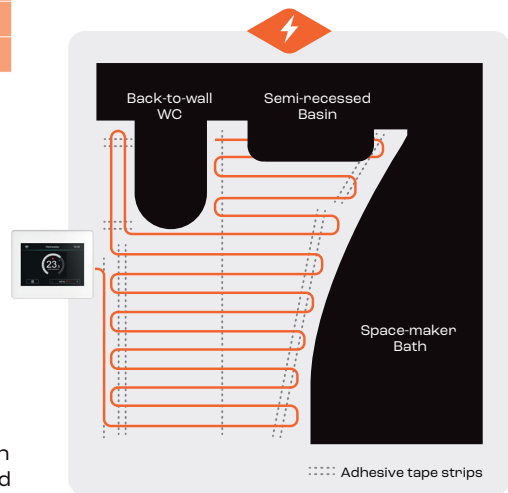

If necessary, you can adjust the spacing, although we recommend that you keep it as regular as possible. Any excess cable can be run around the perimeter of the room. Once installed we recommend another continuity/ resistance check at this stage.

GENERAL INSTRUCTIONS

STEP 4

PLAN WHERE TO PUT THE FLOOR SENSOR

(INCLUDED WITH YOUR THERMOSTATS)

The floor sensor can be found within the thermostat box and is used to read the floor temperature during programming your thermostat. You should install the floor temperature sensor in-between the heating cables, taking care to ensure the floor sensor does not touch the heating elements. This can be achieved by working out the placement of the heating cable prior to fitting the sensor.

When positioning the sensor try to avoid hot water pipes in the floor or any draughty places such as external doorways as this may affect the thermostat. If required, the sensor lead can be extended using twin-flex cable.

The sensor tip must not be placed directly under an element wire. This is to ensure that the average heating temperature is measured, and not the temperature of the heating element.

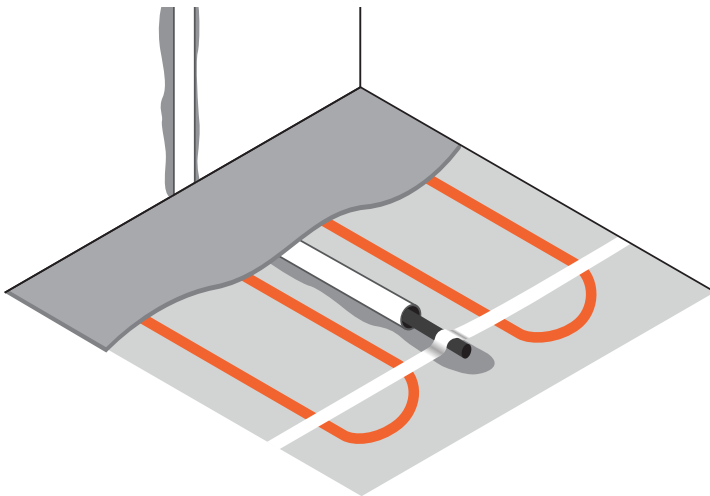

GENERAL INSTRUCTIONS

STEP 5 NOW COVER THE CABLES

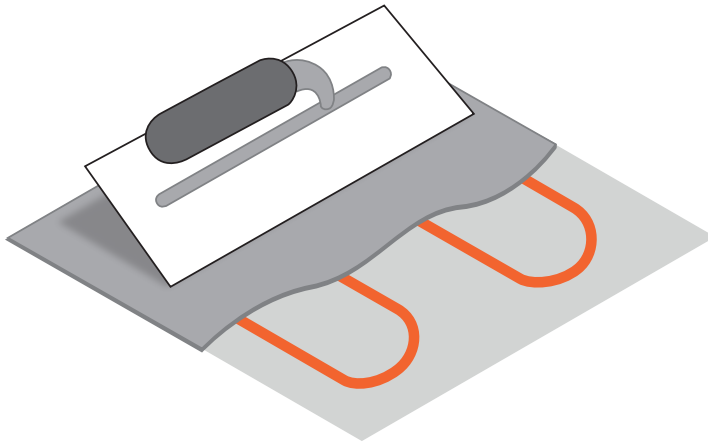

Now the cable is firmly fixed to the sub-floor we highly recommend that you cover the cable with a thin layer of levelling compound or flexible tile adhesive, to avoid the possibility of damage occurring to the heating elements. We suggest testing the system again at this stage. Check with your supplier for the levelling compound and/or tile adhesive suitability for use with underfloor heating and the sub-floor.



NOTE

Check with your supplier for the levelling compound and/or tile adhesive suitability for use with underfloor heating and the sub-floor.

GENERAL INSTRUCTIONS

STEP 6

CONNECTING THE SYSTEM

Now a part P qualified electrician should make the final connections in accordance with IECC guidelines. It is suggested that you use a connection box if more than one system is being connected to the device. The cold leads on the heating cables are not polarised so either can be used as positive/live, however normal practice is to make black or brown positive and blue negative. The cables are of co-axial construction and so have a braided earth screen running all the way through. This is a safety feature and the earth screen must be linked together and connected to the earthing point. All our control units (timer/thermostats) have their own manufacturer's wiring diagrams/instructions enclosed in the packaging. Remember the heating units must be supplied through a residual device (RCD) having a rated residual operating current not exceeding 30mA.



NOTE

Thermostats are normally rated at 16 amps, if you are installing multiple kits, make sure the overall wattage does not exceed 3600 watts.

GENERAL INSTRUCTIONS

STEP 7 TILING

Now you can lay the floor tiles as normal using a suitable flexible tile adhesive. Remember to leave all adhesives to dry naturally, we would recommend waiting for two weeks before turning the heating system on. Once fully cured, we recommend to increase the floor temperature at a rate of 1 degree per day until the desired temperature is reached.

If any tiles need to be taken up for any reason, we recommend that extreme care is taken to avoid damaging the heating system.

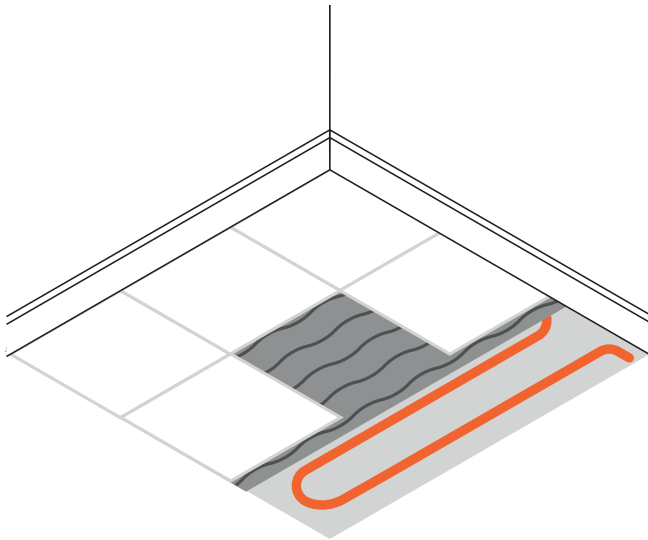

GENERAL INSTRUCTIONS

CONGRATULATIONS!

YOU HAVE INSTALLED YOUR UNDERFLOOR HEATING SYSTEM

Fill in the test cards at the back of this booklet and attach your receipt. This will now act as your guarantee and will be used for reference in the unlikely event of the system malfunctioning.

Should you experience any problems please contact our technical helpline.

If the readings were accurate during the installation, the system will be okay unless accidental damage has occurred during tiling. Should you experience any problems we recommend you check the following:

1 The circuit breaker or fuse is functioning and delivers the power through the thermostat to the heating element.

2 Make sure the RCD has not tripped. If it is a dedicated RCD and it has tripped there is a possibility there could be damage to the cable. Reset the RCD (using the reset button) and, if it trips again contact the technical helpline. **NEVER BYPASS THE RCD.**

3 Check the thermostat is programmed correctly and is switching on. There should be a light on your control to indicate that it is functioning. If the light is on and it is still not functioning, check you have allowed enough time for the floor to heat up.

NOTE



Please note that the Safeguard Guarantee does not cover accidental damage AFTER tiling.

Uninsulated concrete floor

1 hour

Wooden sub-floor

30 minutes

Insulated tile backer boards

20 minutes

These are approximate times and depend on the thickness of the tiles, concrete and insulation that has been put down. If it is the first time you are turning the heating on it can take up to 24 hours for the heat to come through.

If your floor is still not warming up, call the technical helpline and you can speak to one of our engineers.



UNDERFLOOR HEATING

WARRANTY

All of our electrical underfloor heating systems come with a lifetime guarantee, which covers any manufacturing defects for the lifetime of the final floor covering. This warranty covers the repair/replacement of the underfloor heating systems and any associated costs at the discretion of the manufacturer. The ancillary products that we offer to compliment our underfloor heating range are covered by a separate manufacturer warranty (timer/thermostats/RCD's).

Our warranty is subject to the following conditions:

- The warranty is dependent on the ohm's readings on the back of this booklet being completed fully and properly.
- We require proof of purchase to validate the warranty. Therefore, we ask that you retain your invoice, however, if there has been any default in payment for the goods or installation then the warranty is automatically null and void.
- The heating system must always be covered by an RCD (Residual Current Device).
- The system must be fitted in accordance with our installation instructions; failure to install the heating cable in accordance with our installation instructions will invalidate the warranty.
- The warranty does not guarantee heating cables that endure accidental damage before, during or after installation. However, our Safeguard Guarantee protects any accidental damage to the heating cables **BEFORE** installation of the final floor covering.
- If an engineer is required to attend the site to carry out inspections and subsequent repairs to heating systems and the faults are found to be caused by anything other than a manufacturing defect, then we have the right to charge a fair sum for all works carried out.
- The warranty does not cover installations where a part P qualified electrician has not carried out the electrical connection.
- If the cable is damaged during installation you can return it to the store you purchased the cable from and we will replace it free of charge with the same size model (the warranty covers one heater per household/installer). The Safeguard Guarantee does not cover any other type of damage, misuse, or improper installation due to improper adhesive or sub-floor conditions.



We recommend drawing the layout of the heating element after installation, accurately indicating on the drawing where the cable is laid and where you have placed the cold leads / connection cables and floor sensor. Alternatively, you could take a photograph of the installation.

TEST REPORT

- Do not install the heating cables if the temperature is less than +5°C.
- Pay attention to the installation instructions.
- Take care not to damage the cable.

Ensure that the warranty card at the back of the manual is completed and fixed at the main consumer unit along with any plans and electrical test records. As per the current BS7671:2008 17th Edition Wiring Regulations.

| | |
|-------------------------------------|--|
| Name: | |
| Address: | |
| Purchased from: | |
| Date Purchased: | |
| Ohms Reading at start: | |
| Ohms reading when cables installed: | |
| Ohms reading when tiles installed: | |
| Attach receipt | |

WARNING: Your underfloor heating has been designed so that installation is quick and straight forward, but as with all electrical systems, certain procedures must be strictly followed. Please ensure that you have the correct heater(s) for the area you wish to heat. We accept no liability, expressed or implied, for any loss or consequential damage suffered as a result of installations which in any way contravene the instructions. It is important that before, during and after installation that all requirements are met and understood. If the instructions are followed, you should have no problems. If you do require help at any stage, please contact our helpline: 0800 246 5963.

If you need further support please
contact the technical team:

Technical helpline: **0800 246 5963**
Email: **enquiries@riseheating.co.uk**



TÜVRheinland®
Precisely Right.

Tested to: IEC 60335-1:2010+A1+A2 &
IEC 60335-2-96:2019



Type Approved
Safety
Regular Production
Surveillance

www.tuv.com
ID: 1111235051